

产品展示——金雕 G45 动力套件

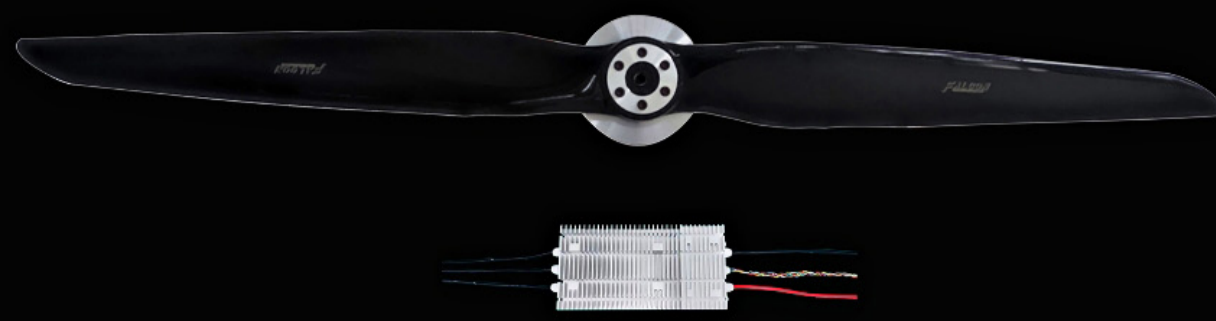

详细参数

电压范围	350~650Vdc	系统力效	6.2g/W
额定拉力	45kg	最大拉力	118kg

电压600Vdc情况

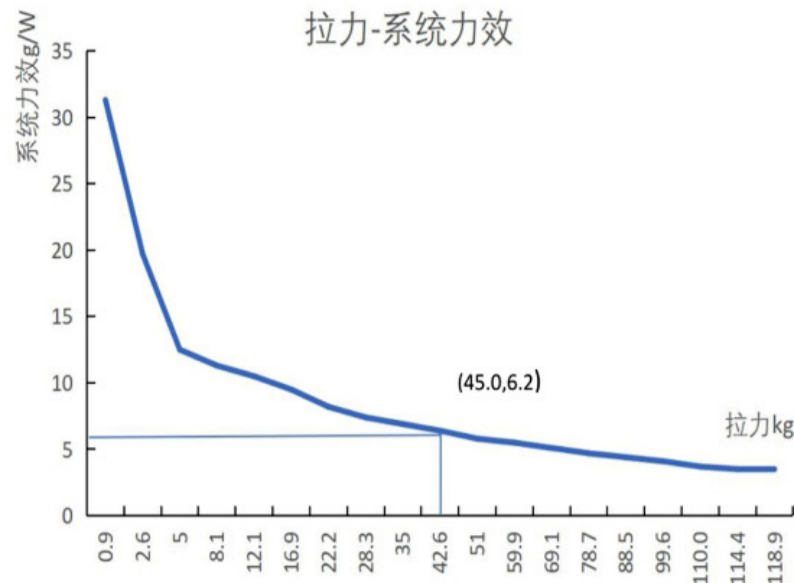
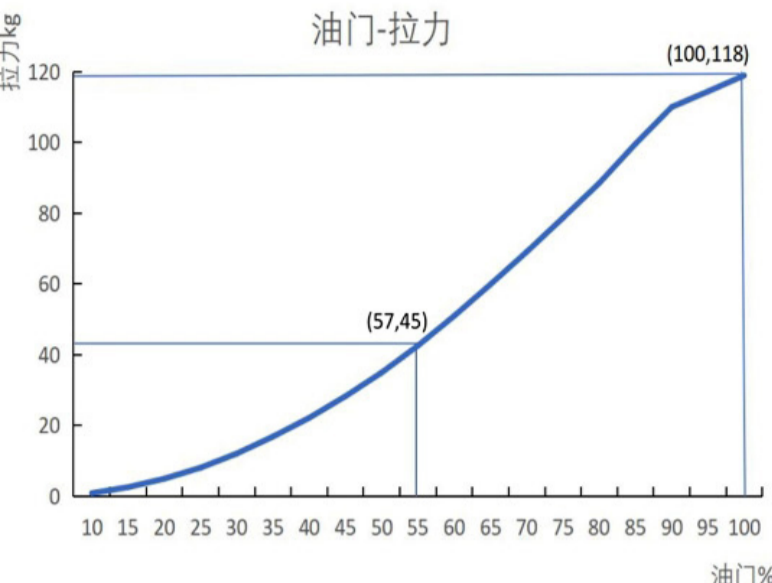

尺寸图

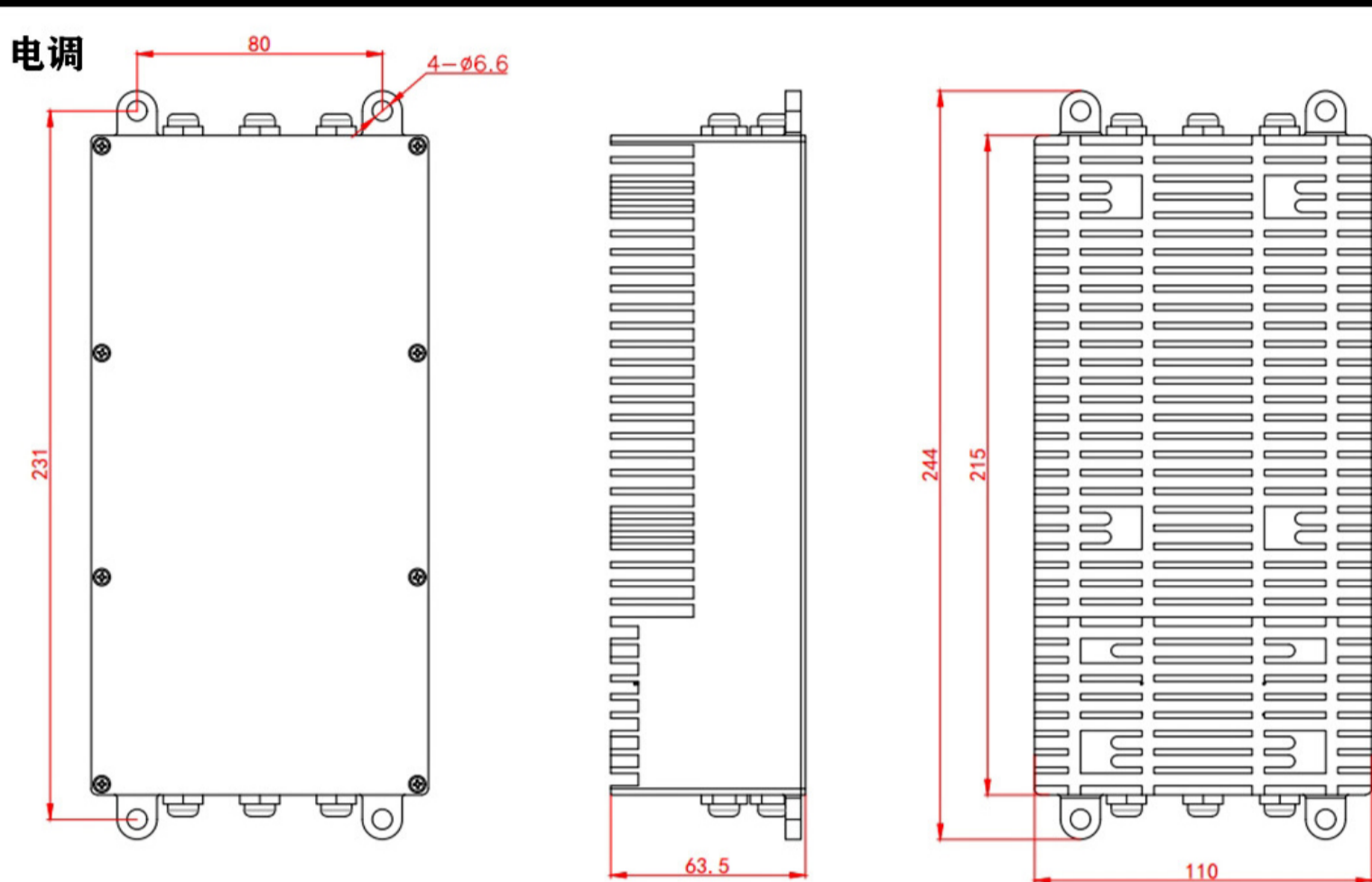

电机

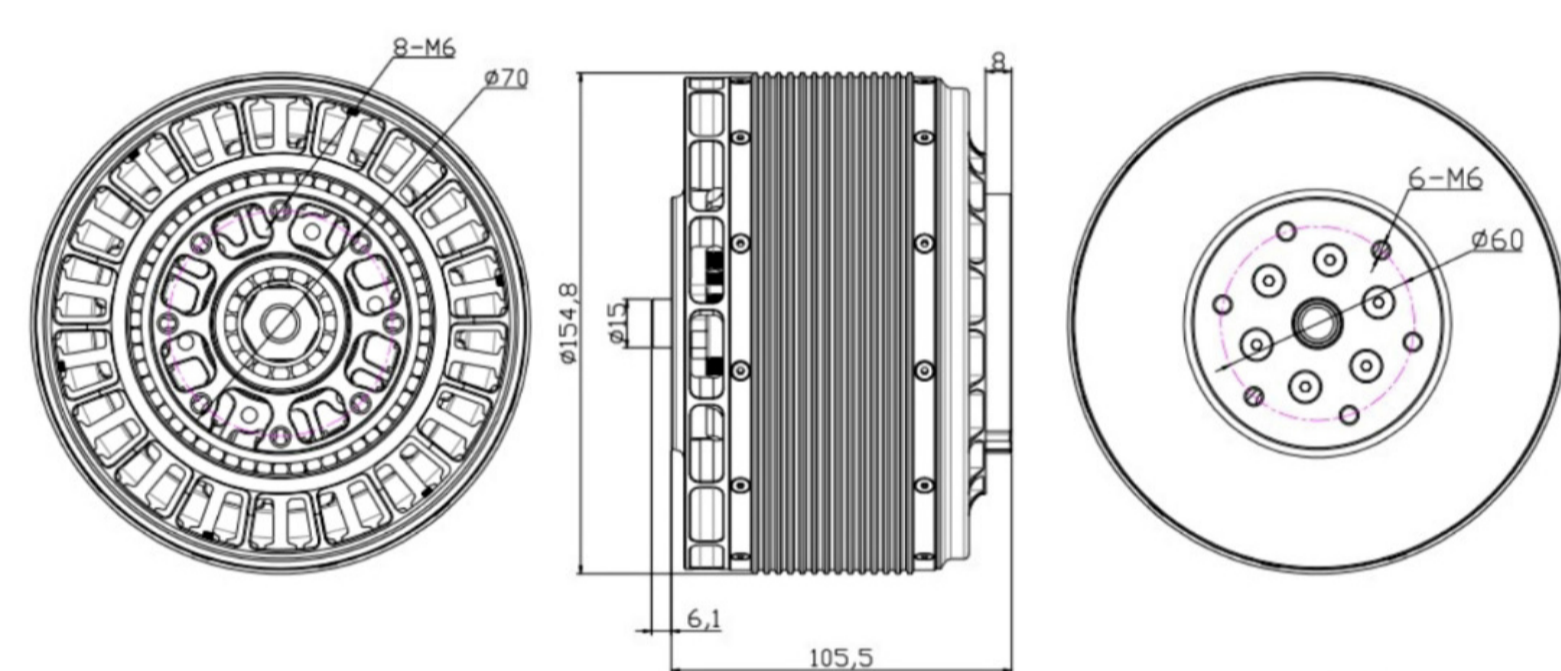

螺旋桨

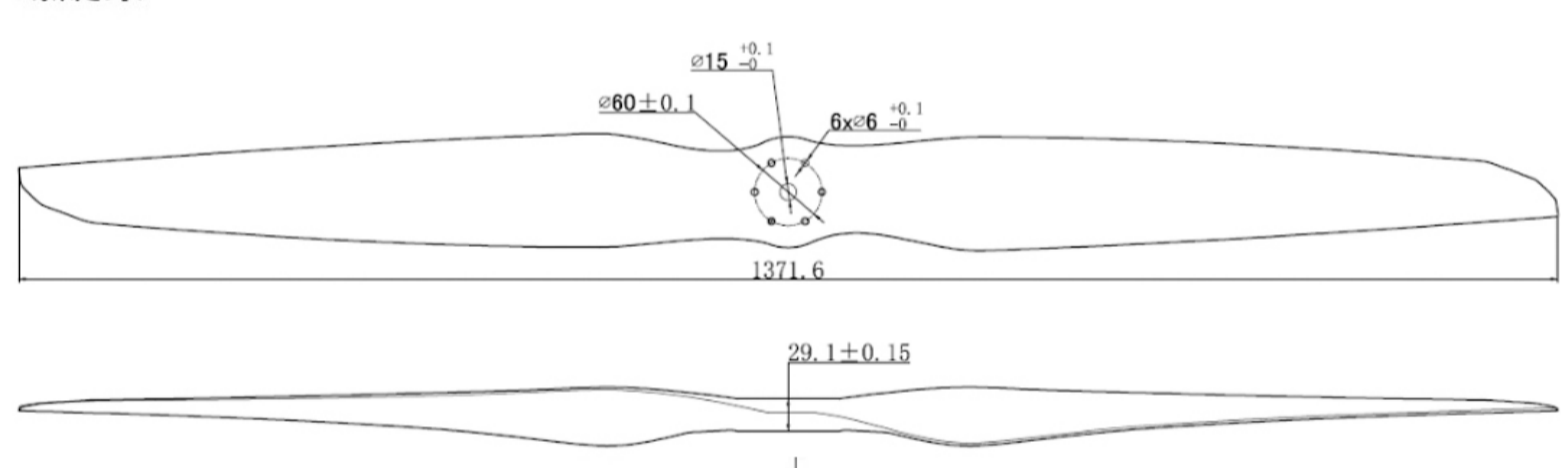

模块参数

电 调

型号	IG1-D3-060-350650-1
重量	1.6kg
外壳尺寸	244mm*110mm*65mm
电压范围	350~650Vdc
额定功率	9.0kW
峰值电流	60A
油门校准行程	支持
电源线	硅胶线-红/黑色-14AWG-37cm*2
输出线	硅胶线-黑色-14AWG-35cm*3
信号线	硅胶线-28AWG

电 机

型号	C14050
KV值	7.2rpm/V
额定功率	10000W
最大功率	22000W
额定电压	400~600Vdc
重量	4500g
内阻	387mohm
磁钢极对数	15

螺旋桨

尺寸	54*24
单支桨重量	830g

测试数据

油门 - %	PWM - us	电压 - V	电流 - A	拉力 - kg	扭矩 - N*m	换相转速 - RPM	总 (电) 功率 - W	轴功率 - W	电机效率 - %	桨力效 - g/W	系统力效 - g/W
10	1192	599	0.05	0.9	0.8	347	30	29	97.1	32.2	31.3
15	1234	599	0.22	2.6	1.89	544	132	108	81.7	24.1	19.7
20	1274	599	0.67	5	3.38	737	401	261	65	19.2	12.5
25	1315	599	1.2	8.1	5.3	926	719	514	71.5	15.8	11.3
30	1356	599	1.92	12.1	7.89	1119	1150	925	80.4	13.1	10.5
35	1397	599	2.98	16.9	10.9	1311	1785	1496	83.8	11.3	9.5
40	1438	598	4.53	22.2	14.36	1500	2711	2256	83.2	9.9	8.2
45	1479	599	6.37	28.3	18.26	1685	3814	3222	84.5	8.8	7.4
50	1520	599	8.47	35	22.63	1869	5071	4429	87.3	7.9	6.9
55	1561	599	11.18	42.6	27.6	2047	6694	5916	88.4	7.2	6.4
60	1602	599	14.63	51	32.94	2224	8756	7672	87.6	6.6	5.8
65	1643	599	18.21	59.9	39.05	2394	10911	9790	89.7	6.1	5.5
70	1684	599	22.84	69.1	45.12	2559	13663	12091	88.5	5.7	5.1
75	1725	599	28.17	78.7	52.02	2725	16860	14845	88	5.3	4.7
80	1766	599	33.62	88.5	58.77	2874	20109	17688	88	5	4.4
85	1807	598	40.81	99.6	67.3	3031	24400	21361	87.5	4.7	4.1
90	1848	598	49.19	110.0	76.01	3178	29406	25296	86	4.3	3.7
95	1889	597	54.01	114.4	81.59	3285	32239	28067	87.1	4.1	3.5
100	1930	597	57.02	118.9	83.79	3299	34047	28947	85	4.1	3.5



智鸥驱动 产品介绍

品类丰富 性能优良 技术先进 支持定制

